

# HYDRUALIC BOLT TENSIONER



TUBE TOOLS



**SHINGARE**  
INDUSTRIES PVT LTD

**MANUFACTURER & EXPORTER OF**  
Tube Cleaners, Tube Tools,  
Tube Expanders, Bolting Tools, Impact Sockets,  
Pipe Beveling Machines, Pipe Cold Cutting Machines,  
High Pressure Water Jet Cleaning Machines & Tapping Machines

Education is necessary but not a pre-requisite for success in life. Bhartiya Industries is the best example of this theory. **Mr. Suryakant Shingare** (HARIBHAI), the founder of the company is a non-matriculate technocrat with more than 10 years experience in flexible shaft manufacturing. He founded this company in 1989.



## Basic Products:

Engineering products is our forte. We manufacture engineering products such as tube expander, tube cleaner, tube tools, hydraulic tube expansion, tube pulling, and pipe beveling machines. We also deal in manufacture of flexible shaft grinders, construction equipment, hydraulic torque wrench, impact socket, pneumatic tapping machines, and many more...

## Brief History of the Company:



We were a small industry until 2003 engaged in production and supply of different types of flexible shafts for tube cleaning, brushes, flexible shaft grinder, and concrete vibrators. The year 2003 was a watershed year for the company.

**Mr. Pradip Shingare**, son of **Mr. Hari Shingare**, graduated from Mumbai University with a degree in Mechanical Engineering. He had great plans to take the company forward on the route to expansion. He ventured into export of the engineering products. By 2008, the company acquired the reputation as the largest exporter of tube cleaning machines and flexible shafts in India.

The year 2009 saw the expansion of the company into manufacture of products such as Tube expander, tube tools, and tube pulling machines. The company witnessed a record double-digit growth in this product range. In 2011, the company started developing a product range of pipe beveling machines. These machines are extremely popular in India as well as in the overseas market. The year 2013 witnessed the company foray into imports of different types of tools such as tapping tools, grinding tools, etc making us the leading player in India in these categories.

The year 2015 saw us entering into the sugar industry component with the manufacture of the Heavy Duty Sugar Dust Collector machine, FlexRepair40 machine.

In 2016, we added **SHINGARE INDUSTRIES PVT. LTD.** a new company in our group. We were awarded ISO 9001:2015 certification for strictly followed quality norms and processes.

## Dedicated Staff:

We have a dedicated team of more than 40 people, many of whom are with us since the early days of the company. We have an excellent blend of youth, knowledge, and experience in our ranks.

## Export oriented:

We export over 60% of our products to more than 55 countries all over the globe.

## Expansion:

We feel the need to expand our business to enable us to serve the people of this country better. With this aim in mind, we established a new company in the name of SHINGARE INDUSTRIES PVT. LTD.

**Our main motto of business is “Growth with Trust.”**

Our mission is to innovate and create an import substitute products in India.



# CONTENTS

Sr. No.	Product	Page
1.	Top Side Bolt Tensioner	4-5
2.	Ts series Multi-Stage Bolt Tensioner	6
3.	Electric Powerpack For Bolt Tensioner (BETP)	7
4.	Air Operated Powerpack For Bolt Tensioner (BATP)	8
5.	Hand Pump For Bolt Tensioner (SHP)	9

## Our Successful Participation in Trade Fairs and Conventions in INDIA and Overseas.



SISSTA BENGALURU 2015



SISSTA, CHENNAI 2016



STAI, NEW DELHI 2016



SISSTA, TIRUPATI 2017



MAHATECH, PUNE 2015

## TOP SIDE BOLT TENSIONER (SBT)

### Features :

- Shingare hydraulic bolt tensioners have eight load cells from M16 to M150 or from 5/8" to 5 3/4"
- Twin ports for quick connection of multiple tools.
- Only one size of bridge per size of load cell.
- Detachable and rotational bridge simplifies bolt tensioner positioning.
- Full bridge window.
- Black surface treatment protects against corrosion
- Anti-slip grip for more secure handling
- Universal and multi-use tool.
- Double Straight Reaction Arm
- Blank Reaction Arm



### Why Tensioning ?

Safe, reliable and repeatable, the use of hydraulic tensioners has many advantages over other less accurate tightening methods.

- Tension is applied directly to stretch the bolt, so we don't need to fight against friction or losses.
- The applied load is controlled very accurately, because it is directly proportional to the pressure applied to the tensioner.
- The load transfer factor is calculable, helping to give the correct residual load.
- Operation of tooling and improved accuracy reduces time required to retighten the load.
- Tensioning allows for loading multiple fasteners in a joint at the same time.
- Uniform bolt loading ensures a high level of accuracy by applying a constant force.
- Purely axial, tensile loading ensures no torsional stresses are introduced.

## SHINGARE BOLT TENSIONER (SBT)

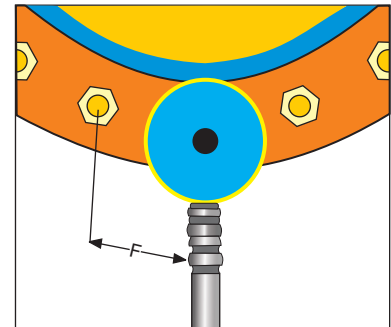
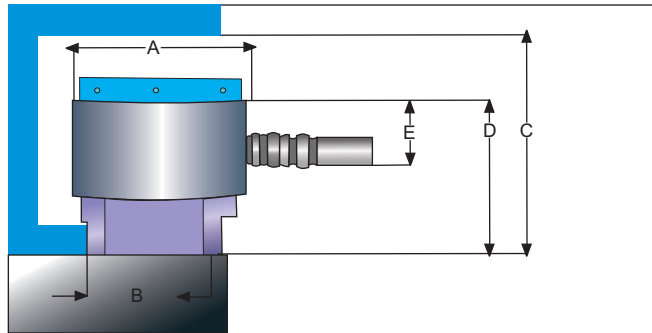

Model	Bolt Size		Cylinder Tons	Area Cm2	Dimension						Weight Kg
	Metric	Inch			A	B	C	D	E	F	
SBT-3	M16	-	23.5	15.7	75	32.5	168	90	62	47-51	2
	M18	3/4"									
	M20	-									
	M22	7/8"									
	M24	1									
SBT-5	M27	1-1/8"	50	33	102	47	187	106	60	65-71	4
	M30	-									
	M33	1-1/4"									
	M36	1-3/8"									
	M39	1-1/2"									
SBT-9	M39	1-1/2"	90	59.7	133	61	208	120	60	86-93	6
	M42	1-5/8"									
	M45	1-3/4"									
	M48	1-7/8"									
SBT-13	M52	2"	130	83	163	73	231	135	62	106-114	10
	M56	2-1/4"									
	M60	-									
	M64	2-1/2"									
SBT-19	M64	2-1/2"	190	123	193	86.5	254	150	62	129-135	15
	M68	-									
	M72	2-3/4"									
	M76	3"									
SBT-27	M76	3"	270	176	233	110	286	180	73	155-167	24
	M80	-									
	M85	3-1/4"									
	M90	3-1/2"									
	M95	3-3/4"									
M100	4"										
SBT-44	M110	4-1/2"	440	251	280	111-121	304-338	181-197	37-40	210-233	45
	M120	4-3/4"									
	M125	5"									
SBT-54	M130	5-1/4"	540	317	325	126-141	354-388	202-216	42-47	243-275	73
	M140	5-1/2"									
	M150	5-3/4"									

## TS SERIES MULTI-STAGE BOLT TENSIONERS

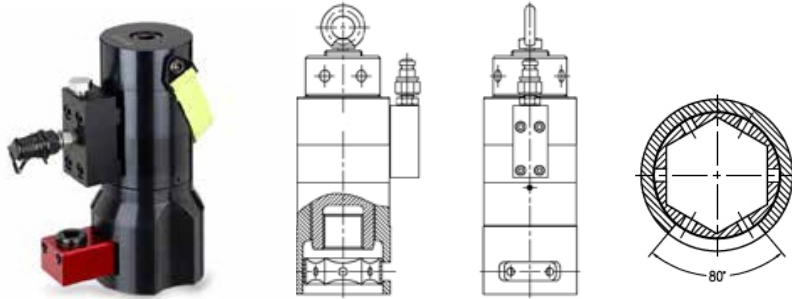

### Features and benefits

- Relatively smaller dimension with higher.
- Multi-stage design, maximize the tensioning Length
- Suitable for single type bolt tensioning, high
- Max. Pressure: 1500 Bar
- Can be operated with ultra high pressure hand pump, air pump and electric pump

Customers can fill the form below for us to chose the right desgin of multi-stage bolt tensioners for your solutions.

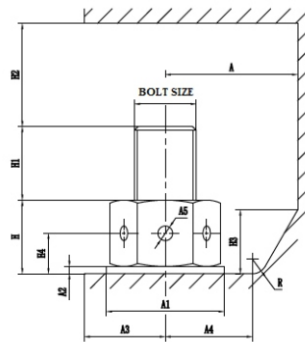

THREAD \_\_\_\_\_ .  
 ADJACENT BOLT CENTER DISTANCE \_\_\_\_\_ mm.  
 BOLT TYPE(ROUND/HEX) \_\_\_\_\_ .  
 BOLT SIZE \_\_\_\_\_ .  
 BOLT TENSION FORCE \_\_\_\_\_ KN.  
 BOLT QTY. \_\_\_\_\_ .  
 WORKING TEM. \_\_\_\_\_ OC .

A: \_\_\_\_\_ MM  
 A1: \_\_\_\_\_ MM  
 A2: \_\_\_\_\_ MM  
 A3: \_\_\_\_\_ MM  
 A4: \_\_\_\_\_ MM  
 A5: \_\_\_\_\_ MM

H: \_\_\_\_\_ MM  
 H1: \_\_\_\_\_ MM  
 H2: \_\_\_\_\_ MM  
 H3: \_\_\_\_\_ MM  
 H4: \_\_\_\_\_ MM  
 R: \_\_\_\_\_ MM

## ELECTRIC POWERPACK FOR BOLT TENSIONER (BETP)



### Features of Power Pack:

- Brand new technology: Combine unit of Low pressure and high pressure equipments.
- Less High pressure component used, hence maintenance cost is less.
- All components are Highly precise and reputed make.
- Substantial savings in energy and oil consumption.
- Analog or Digital pressure gauges assure the highest possible read out and adjustment precision.
- High speed/flow.
- Remotely operation forward and reverse.
- Light weight & compact design.

### Optional Accessories:

- High pressure hose
- High pressure QRC (Quick Release Coupling)
- Digital Pressure Gauge

**Tensioning Pump - Model BETP-1500 (Tensioning Pump)**

Tensioning Pump - Model BETP-1500 (Tensioning Pump)		
<b>Pump</b>		
Main Voltage	AC	230 V, 50Hz
Solenoid Voltage	AC	230 V
Main Consumption	A	10
Motor Capacity	kW	1.5
Protected According to	IP	IP 55
Nominal Pressure	bar	0-1500
<b>Flow</b>		
Flow @ 1500 Bar	lpm	0.1 @ 1500 bar
Tank Volume	litre	14
Oil Type		Servo 68
Ambient Temperature	C	45°
Max Oil Temperature	C	60°
<b>Weight</b>		
Weight without oil	Kg	35 Approx

## BHARTIYA AIR OPERATED TENSIONER PUMP (BATP)



The air operated powerpack for bolt tensioner BATP-1500 are designed to meet the highest technical and safety requirements of high pressure equipment.

### Technical Features

- **Stainless Steel Frame:** The hydraulic unit is installed in a weather proof stainless steel protection frame.
- **Logical Control Panel:** Logical layout design engraved for easy operation.
- **Calibrated Pressure Gauge:** Calibrated 150mm (6"), liquid filled, SS Frame, 2500 bar rating pressure gauge with dual reading of bar & psi.
- **Complete Air System:** System includes FRL Unit, air pressure gauge and control knob for safe air control and supply.
- **Higher Operating Pressure:** Pump has max working pressure of 1500 bar to cover all bolt tensioning applications.
- **Light Weight:** Unit weighs only 18 Kg and measures 450mm x 340mm x 480mm.
- **Lower Input air Pressure:** Higher pressure ratio of 1 : 350 ensures less input air pressure for operation.
- **Quick Connect Outlet:** Pump comes fitted with quick connect outlet for easy connection of hydraulic hose.

### Optional Accessories:

- High pressure hose
- High pressure QRC (Quick Release Coupling)
- Digital Pressure Gauge

### Technical Details - Model BATP-1500 (Bhartiya Air Operated Tensioner Pump)

Technical Details - Model BATP-1500 (Bhartiya Air Operated Tensioner Pump)		
<b>Pump</b>		
Pressure Ratio		1:350
Displacement Volume	cm <sup>3</sup>	1.3
Operating Pressure, Max. ( at 5.1 bar Pre Limited (PL) Air Pressure )	bar	1800
<b>Compressed air supply (air drive)</b>		
System Operating Air Pressure, Max.	bar	5.1
Safety Valve Set Pressure	bar	5.5
<b>Stainless Steel Tank Capacity</b>		
Oil Tank capacity	litre	5



## HAND PUMP FOR BOLT TENSIONER (SHP)



The SHINGARE double stage hand pumps comes with pressure gauge as standard, this gives the user precise and safe control over the work carried out. The gauge is directly mounted onto the pump and is well protected by the specially designed pump lever.

### Features

- Return connections on all pumps.
- Robust design
- Aluminium tank.
- Easy and simple maintenance

**Model No. : SHP**

**Maximum Working Pressure :- 1600 Bar**

Pump Type	Usable Oil Capacity	Model Number	Pressure Rating		Output Oil Volume Each Stroke		Handle Force	Dimensions (mm)			Output Adapter	Weight
			(Bar)		(cm <sup>3</sup> )							
	(cm <sup>3</sup> )	Nm	1st Stage	2nd Stage	1st Stage	2nd Stage	(N)	A	B	C	(Kg)	
Double Speed	655	SHP 7 - 0.7	25	700	15	2.6	300	520	133	119	NPT 3/8" G 1/4"	5.3
	1440	SHP 7-1	25	700	32	2.5		577	120	170		6.3
	2200	SHP 7-2	25	700	16	2.5		539	146	170		8
	3240	SHP 7-3	25	700	32	2.5		582	200	170		10
	5860	SHP 7-4	25	700	32	2.5		667	250	172		14.5
	7500	SHP 7-8	14	700	126	4.8		742	308	270		27
	1440	SHP 16-1	15	1600	32	2.5	375	577	577	170		6.3
	3240	SHP 16-3	15	1600	32	2.5		577	140	190		10

## OUR MAJOR CLIENTS

Please see below our robust and valued client list that uses BHARTIYA products repeatedly. We take pride in our partnerships and the ability to grow with such amazing group of companies.



**SHINGARE**  
INDUSTRIES PVT LTD

 **SHINGARE INDUSTRIES PVT. LTD.**  
Formerly known as Bharatiya Industries

 Manufacturer & Exporter of Tube Cleaners, Flexible Shafts, Tube Tools, Pipe Beveling Machines, Torque Tools, Grinding Tools, Tapping Tools.

 A-48 B Osiya Mataji Compound, Village Kalher, Retibunder Road, Tal. Bhiwandi, Dist. Thane - 421302, Maharashtra,

 +91 22 25854509 | +91 90290 05461  +91 22 25883527  bharatflex@yahoo.com | spradip@tubecleaner.co.in

 [www.shingare.com](http://www.shingare.com) | [www.tubecleaner.co.in](http://www.tubecleaner.co.in)

*Authorised Dealer*